



ARCHITECTURAL & ENGINEERING SPECIFICATION

The Nachi® foaming soap dispenser - With its sleek and simple design, its the perfect companion for matching Nachi® faucet, offering a user-friendly, automatic hand-washing experience. ADA compliant for universal access, this chrome-plated foaming soap dispenser can be powered by batteries or an A/C adapter, making it an ideal choice for both retrofit and new construction projects.

PRODUCT FEATURES

- Heavy duty one piece construction
- Long life internal pump
- 80K cycle battery life
- Comes with A/C Adapter
- 4 "D" size alkaline included
- Foaming liquid hand soap (sold separately)
- Four Adjustable dispensing amounts
- 1600ml [54.1 oz] refillable soap bottle
- Complements Nachi® Z6957-XL faucet series

COMPLIANCE AND CERTIFICATION

- ADA Compliant



Z6957-FSD

ALTERNATE FINISHES

- BN Brushed Nickel
- MB Matte Black

OPTIONAL ACCESSORIES

- P6900-SD-BKT Stud Mounting Kit

ARCHITECTURAL & ENGINEERING APPROVAL

The information contained in this document is subject to change without notice. Please contact Zurn for most up to date information.

Rough-in dimensions/Overview dimensions

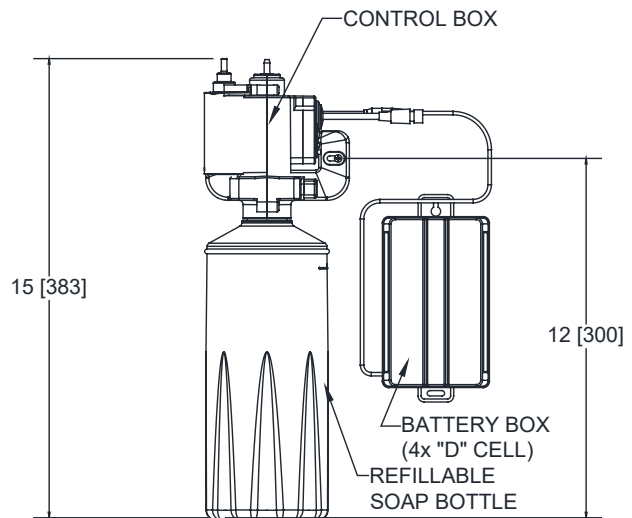
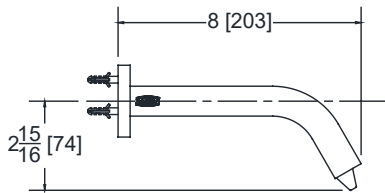
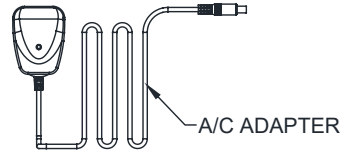

Note: Recommended mounting through hole is 5/8" - 1"

Typical Z6957-FSD